

# OptiPure

Model: **QTSFT-3+**  
Part #: 160-00460

## Snapshot

The QTSFT-3+ is a unique water softening system that allows precision blending of filtered water with softened water allowing the user to adjust the water hardness to a desired level. The system utilizes high-capacity ion-exchange resin to remove hardness minerals and an activated carbon filter reduces dirt and sediment down to 0.5-microns and reduces chlorine, off-taste and odor. The system incorporates a multi-turn precision metering valve and electronic flowmeter to provide a predictable and reliable blend during the life of the media.

## System Benefits

- Takes out hardness minerals that form damaging scale (lime-scale).
- Precision Multi-Turn Metering Valve allows precise and consistent blending of filtered water with softened water.
- Adjustable Digital Flow Meter measures gallons used and alerts with audible and visual alarm when filters need to be changed. Flow rate, elapsed time, near end of life, end of life and low battery alerts are also provided. No guessing about filter life.
- Reduces maintenance frequency and cost, and extends equipment life.
- Compact design makes wall-mount or under-counter installation simple.
- Built-in flush valve simplifies service and enables quick hardness testing.
- Utilizes Qwik-Twist cartridges that make changing filters quick, easy and sanitary.
- Includes professional water hardness test kit (100 tests).

ITEM #: \_\_\_\_\_ QTY: \_\_\_\_\_  
JOB NAME/NUMBER \_\_\_\_\_



## Application

ESPRESSO MACHINES

TEA BREWERS

BUN WARMERS AND SMALL TABLE-TOP STEAMERS

## Installation Tips

- Feed-water connection to system should be COLD only.
- Do not exceed system specifications for temperature and pressure.
- Allow 3" clearance below system for filter cartridge removal and replacement.
- Detailed installation, operation and maintenance manual included with each system.
- Flush system at a low flow rate for 5 minutes or until water runs clear.

# OptiPure

Model: **QTSFT-3+**  
Part #: 160-00460

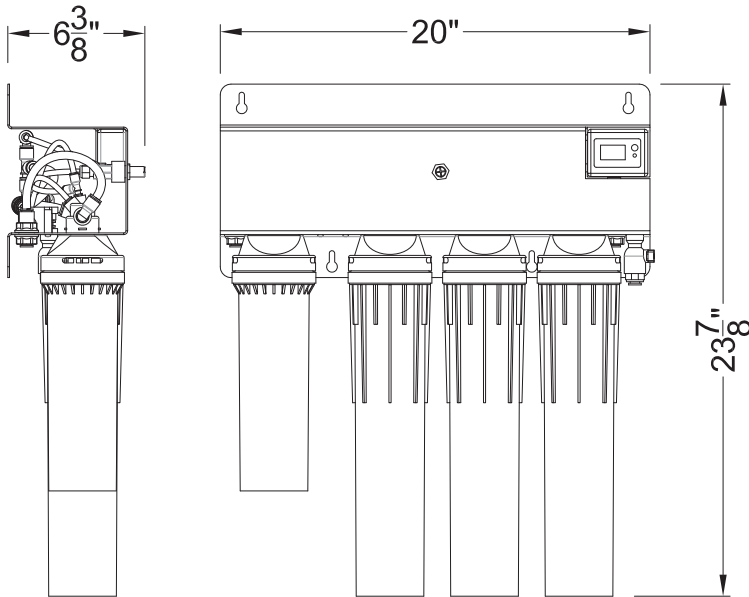

Capacity of QTSFT-3+				
Feed Hardness GPG (MG/L)	Blend Hardness GPG (MG/L)	Gallon Capacity	Blend Hardness GPG (MG/L)	Gallon Capacity
25 (428)	3 (51)	236	5 (86)	260
20 (342)	3 (51)	306	5 (86)	347
17 (291)	3 (51)	371	5 (86)	433
15 (257)	3 (51)	433	5 (86)	520
12 (205)	3 (51)	578	5 (86)	743
10 (171)	3 (51)	743	5 (86)	1040
9 (154)	3 (51)	867	5 (86)	1300
8 (137)	3 (51)	1040	5 (86)	1733
7(120)	3 (51)	1300	5 (86)	2600
6 (103)	3 (51)	1733	5 (86)	5200

**WARNING:**  
Cancer and Reproductive Harm -  
[www.P65Warnings.ca.gov](http://www.P65Warnings.ca.gov).

## Warranty

All system components and assembly except for filter cartridges, separation membranes, permeate pumps, electric motors, diaphragm pumps, and rotary vane pumps shall be warranted against defects in workmanship for a period of 60 months from the date of original shipment. For complete warranty information, contact OptiPure customer service or go to [www.optipurewater.com](http://www.optipurewater.com).

Dealer/Distributor Info:

## Specifications

System	
Dimensions (Height x Width x Depth, Inches)	23.9"h x 20"w x 6.4"d
Connection - Inlet & Outlet	3/8" Push Fit
Operating Pressure Range	10 - 125 psi (0.7 - 8.6 bar)
Inlet Water Temperature Range	35° - 100° F (2° - 38° C)
Shipping Weight	24 lbs.
Performance	
Chlorine, Taste and Odor Reduction Capacity	15,000 gals. (56,775 L)
Service Flow Rate	1.00 gpm (3.78 lpm)
Sediment Reduction	1 micron (nominal)
Hardness Removal	5,200 grains

## Replacement Cartridge(s)

Model	Part Number	Qty
CTO-Q10	300-08110	1
SFT-Q	300-08250	3

## Options

Model	Description	Part Number
Flush Valve Kit	QT Flush Valve Kit	160-52912

It is recommended that pre/post-filters and mineral addition cartridges are changed every 6 months, when capacity is reached or when feedwater pressure or flow becomes inadequate.

Membrane life varies depending on feedwater conditions and pre-filter maintenance. It is 12-18 months under typical conditions, but it can be as long as 3-5 years.

This product is for commercial use only and must be installed and maintained according to manufacturer's guidelines.

Do not use on water that is microbiologically unsafe or of unknown quality without adequate disinfection before or after the system.

## OptiPure, A Division of Aquion, Inc.

101 S. Gary Ave., Suite A  
Roselle, IL 60172

p: 972.881.9797 e: [info@optipure.net](mailto:info@optipure.net)  
[www.optipurewater.com](http://www.optipurewater.com)