

OptiPure

Snapshot

The QTI10-1 is a single-cartridge water treatment system with a 10" Qwik-Twist cartridge that reduces sediment down to 0.5-microns and reduces chlorine, taste & odor at a flow rate of 1.5 gpm for 15,000-gallons. The system includes IsoNet®, OptiPure's patented scale inhibiting technology, which delivers consistent protection against the precipitation and accumulation of scale and provides a protective barrier to help guard against corrosion.

System Benefits

- IsoNet® - OptiPure's patented scale inhibiting technology helps protect equipment against scale and corrosion for the rated capacity of the system.
- Reduces maintenance frequency and cost, and extends equipment life.
- Gradient-density sediment filtration protects against dirt, rust and other debris down to 0.5-microns.
- High-capacity activated-carbon filtration makes water taste great and protects equipment against corrosive chlorine.
- Sturdy mounting bracket and full-flow inlet shut-off valve simplify installation.
- Built-in pressure gauge allows visual monitoring of when filters need to be changed.
- Inlet shut-off valve makes filter replacement quick and simple.
- Utilizes Qwik-Twist cartridges that make changing filters quick, easy and sanitary.
- NSF Certified under Standard 42.

Model: **QTI10-1**
Part #: 160-52011

ITEM #: _____ QTY: _____

JOB NAME/NUMBER: _____



Application

ICE - Cubers up to 800 lbs. and Flakers up to 1,000 lbs.

COFFEE - Single or multiple Brewers up to 1.5 gpm.

STEAM AND COMBI OVENS

Installation Tips

- Feed-water connection to system should be COLD only.
- Do not exceed system specifications for temperature and pressure.
- Allow 3" clearance below system for filter cartridge removal and cartridge replacement.
- Connect filtered water line to ice or steam connections only. Do not use for condenser water.
- Detailed installation, operation and maintenance manual included with each system.
- No activation procedure or flushing required for system to perform as specified.

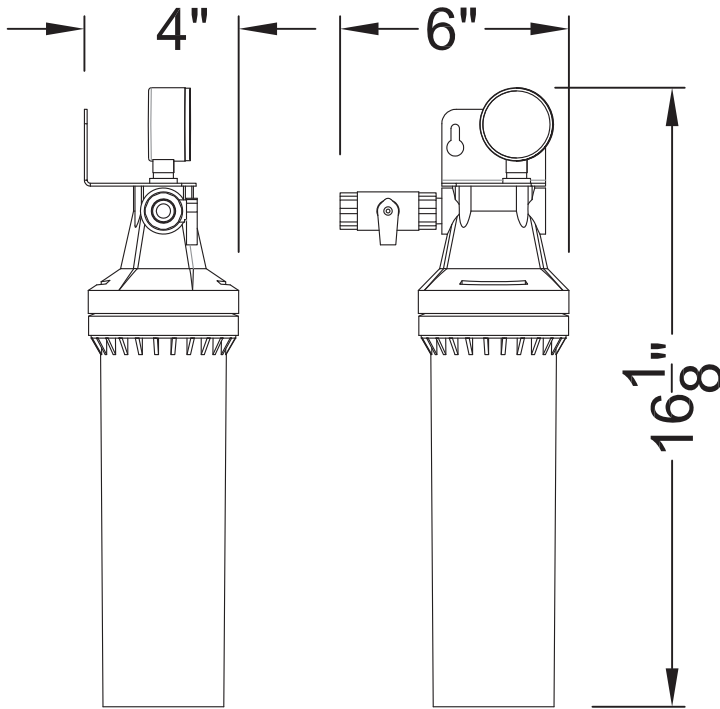

System Tested and Certified by NSF International against NSF/ANSI Standard 42 Aesthetic Effects - Particulate Reduction (Class I) and the reduction of Chlorine, Taste and Odor.



WARNING:
Cancer and Reproductive Harm -
www.P65Warnings.ca.gov.

▶ Warranty

All system components and assembly except for filter cartridges, separation membranes, permeate pumps, electric motors, diaphragm pumps, and rotary vane pumps shall be warranted against defects in workmanship for a period of 60 months from the date of original shipment. For complete warranty information, contact OptiPure customer service or go to www.optipurewater.com.

Dealer/Distributor Info:

▶ Specifications

System	
Dimensions (Height x Width x Depth, inches)	16.1" h x 6" w x 4" d
Connection - Inlet & Outlet	3/8" NFPT
Operating Pressure Range	10 - 125 psi (0.7 - 8.6 bar)
Inlet Water Temperature Range	35° - 100° F (2° - 38° C)
Shipping Weight	3 lbs.
Performance	
Chlorine, Taste and Odor Reduction Capacity	15,000 gals. (56,750 L)
Service Flow Rate	1.50 gpm (5.65 lpm)
Sediment Reduction	0.5 microns (nominal)
Scale & Corrosion Inhibitor	IsoNet (70 grams)

▶ Replacement Cartridge(s)

Model	Description	Part Number	Qty
CTOS-Q10	Filter	300-05829	1

▶ Options

Model	Description	Part Number
Flush Valve Kit	QT Flush Valve Kit	160-52912

It is recommended that pre/post-filters and mineral addition cartridges are changed every 6 months, when capacity is reached or when feedwater pressure or flow becomes inadequate.

Membrane life varies depending on feedwater conditions and pre-filter maintenance. It is 12-18 months under typical conditions, but it can be as long as 3-5 years.

This product is for commercial use only and must be installed and maintained according to manufacturer's guidelines.

Do not use on water that is microbiologically unsafe or of unknown quality without adequate disinfection before or after the system.

OptiPure, A Division of Aquion, Inc.

101 S. Gary Ave., Suite A
Roselle, IL 60172

p: 972.881.9797 e: info@optipure.net
www.optipurewater.com