

# OptiPure

## Snapshot

The FX-22BCR is a dual-housing water treatment system with drop-in 4.5" x 20" cartridges that reduces sediment down to 5-microns and reduces chlorine, chloramines, taste & odor at a flow rate of 5.0 gpm for 25,000-gallons. The system includes a granular catalytic carbon filter for reduction of chloramines.

## System Benefits

- Improves quality and consistency of cold and hot beverages.
- Reduces maintenance frequency and cost, and extends equipment life.
- Catalytic-carbon filtration provides added protection against chloramines that may be present in water supplies.
- Gradient-density sediment filtration protects against dirt, rust and other debris down to 5-microns.
- Sturdy, powder-coated mounting bracket and full-flow inlet shut-off valve simplify installation.
- Built-in pressure gauge allows visual monitoring of when filters need to be changed.

Model: **FX-22BCR**

Part #: 160-50049

ITEM #: \_\_\_\_\_ QTY: \_\_\_\_\_

JOB NAME/NUMBER: \_\_\_\_\_



## Application

**FOUNTAIN BEVERAGES** - Any application requiring chloramine reduction / multiple carbonators up to 5.0 gpm flow rate. Includes granular catalytic carbon filter for water supplies that use chloramines for disinfection.

## Installation Tips

- Feed-water connection to system should be COLD only.
- Do not exceed system specifications for temperature and pressure.
- Allow 3" clearance below system for filter housing removal and cartridge replacement.
- Detailed installation, operation and maintenance manual included with each system.



Model: **FX-22BCR**  
Part #: 160-50049

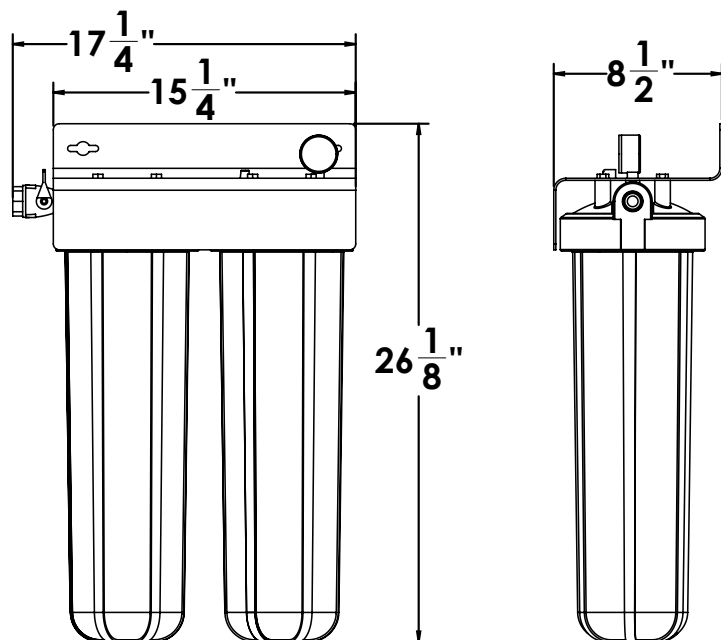

**WARNING:**  
Cancer and Reproductive Harm -  
[www.P65Warnings.ca.gov](http://www.P65Warnings.ca.gov)

## ► Specifications

System	
Dimensions (Height x Width x Depth, Inches)	26" h x 17.8" w x 8.5" d
Connection - Inlet & Outlet	3/4" NPT
Operating Pressure Range	10 - 125 psi (0.7 - 8.6 bar)
Inlet Water Temperature Range	35° - 100° F (2° - 38° C)
Shipping Weight	38 lbs.
Performance	
Chloramine, Chlorine, Taste and Odor Reduction Capacity >85+%	25,000 gals. (94,500 L)
Service Flow Rate	5.0 gpm (18.9 lpm)
Sediment Reduction	5 microns (nominal)

## ► Replacement Cartridge(s)

Model	Description	Part Number	Qty
CCM-20B	Filter	252-20605	1
CTO-20B	Filter	252-20420	1

## ► Options

Model	Description	Part Number
Flush Valve Kit	FX Flush Valve Kit	160-52910

It is recommended that pre/post-filters and mineral addition cartridges are changed every 6 months, when capacity is reached or when feedwater pressure or flow becomes inadequate.

Membrane life varies depending on feedwater conditions and pre-filter maintenance. It is 12-18 months under typical conditions, but it can be as long as 3-5 years.

This product is for commercial use only and must be installed and maintained according to manufacturer's guidelines.

Do not use on water that is microbiologically unsafe or of unknown quality without adequate disinfection before or after the system.

## ► Warranty

All system components and assembly except for filter cartridges, separation membranes, permeate pumps, electric motors, diaphragm pumps, and rotary vane pumps shall be warranted against defects in workmanship for a period of 60 months from the date of original shipment. For complete warranty information, contact OptiPure customer service or go to [www.optipurewater.com](http://www.optipurewater.com).

Dealer/Distributor Info:

**OptiPure, A Division of Aquion, Inc.**  
101 S. Gary Ave., Suite A  
Roselle, IL 60172  
p: 972.881.9797 e: [info@optipure.net](mailto:info@optipure.net)  
[www.optipurewater.com](http://www.optipurewater.com)