

OptiPure

Snapshot

The FXAF01-12B is a single-housing water treatment system with a drop-in 4.5" x 20" high-capacity, dual-density sediment cartridge that takes out dirt, rust and other particulates down to 1-micron. The system can be used as a point-of-use sediment reduction filter; or it can be applied prior to a primary filtration system to provide additional pre-filtration to protect against premature plugging due to excessive dirt and sediment levels found in some water supplies. System includes a pressure gauge, inlet ball valve and mounting bracket.

System Benefits

- Gradient-density sediment filtration protects against dirt, rust and other debris down to 1-micron.
- Protects down-line filtration systems against premature plugging, reducing filter change frequency and associated cost.
- Sturdy mounting bracket and full-flow inlet shut-off valve simplify installation.
- Built-in pressure gauge allows visual monitoring of when filters need to be changed.
- Inlet shut-off and depressurization valves make filter replacement quick and simple.
- Minimizes waste by only replacing drop-in cartridge and reusing filter sump.

Model: **FXAF01-12B**

Part #: 160-50345

ITEM #: _____ QTY: _____

JOB NAME/NUMBER _____



Application

ALL EQUIPMENT APPLICATIONS - When excessive sediment is a problem.

EXISTING FILTRATION SYSTEMS - Provides added pre-filtration to extend filter life.

Installation Tips

- Feed-water connection to system should be COLD only.
- Do not exceed system specifications for temperature and pressure.
- Allow 3" clearance below system for filter housing removal and cartridge replacement.
- Detailed installation, operation and maintenance manual included with each system.
- No activation procedure or flushing required for system to perform as specified.



Model: **FXAF01-12B**
Part #: 160-50345

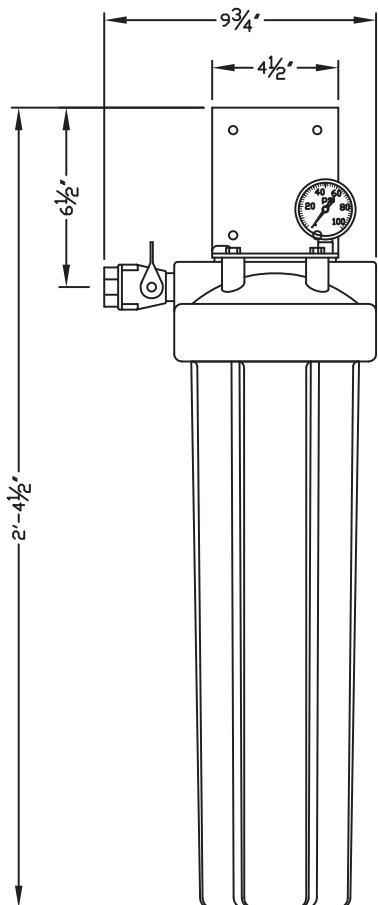

WARNING:
Cancer and Reproductive Harm -
www.P65Warnings.ca.gov.

► Specifications

System	
Dimensions (Height x Width X Depth, Inches)	24.5" h x 9.8" w x 5.1" d
Connection - Inlet & Outlet	3/4" FNPT
Operating Pressure Range	10 - 125 psi (0.7 - 8.6 bar)
Inlet Water Temperature Range	35° - 100° F (2° - 38° C)
Shipping Weight	18 lbs.
Performance	
Chlorine, Taste and Odor Reduction Capacity	N/A
Service Flow Rate	8.0 gpm (30.3 lpm)
Sediment Reduction	1 micron (nominal)
Scale & Corrosion Inhibitor	N/A

► Replacement Cartridge(s)

Model	Part Number	Qty
S1-20B	252-10405	1

► Options

Model	Description	Part Number
Flush Valve Kit	FX Flush Valve Kit	160-52914

It is recommended that pre/post-filters and mineral addition cartridges are changed every 6 months, when capacity is reached or when feedwater pressure or flow becomes inadequate.

Membrane life varies depending on feedwater conditions and pre-filter maintenance. It is 12-18 months under typical conditions, but it can be as long as 3-5 years.

This product is for commercial use only and must be installed and maintained according to manufacturer's guidelines.

Do not use on water that is microbiologically unsafe or of unknown quality without adequate disinfection before or after the system.

► Warranty

All system components and assembly except for filter cartridges, separation membranes, permeate pumps, electric motors, diaphragm pumps, and rotary vane pumps shall be warranted against defects in workmanship for a period of 60 months from the date of original shipment. For complete warranty information, contact OptiPure customer service or go to www.optipurewater.com.

Dealer/Distributor Info:

OptiPure, A Division of Aquion, Inc.
101 S. Gary Ave., Suite A
Roselle, IL 60172
p: 972.881.9797 e: info@optipure.net
www.optipurewater.com